

HOFMANN®

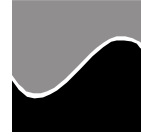

TrueCut 201

**OPERATING
INSTRUCTIONS
MANUAL**

TABLE OF CONTENTS

SAFETY INSTRUCTIONS	2-4
INSTALLATION & SET-UP	5-6
MOUNTING BRAKE DRUMS	7
OPERATING LATHE (DRUMS)	8-10
MOUNTING BRAKE ROTORS	11
COMPOSITE ROTORS	12
NON-DIRECTIONAL FINISH	12
OPERATING LATHE (ROTORS)	13-15
ARBOR REMOVAL & INSTALLATION	16
SERVICE & MAINTENANCE	17
TROUBLE SHOOTING	18-21
STANDARD TOOLING	22
WIRING DIAGRAM	23

IMPORTANT SAFETY INSTRUCTIONS

Before operating this lathe, basic safety precautions should always be followed, including the following:

READ ALL INSTRUCTIONS

Do not operate equipment with a damaged cord or if equipment has been dropped or damaged, until it has been examined by a qualified service man.

To reduce the risk of electric shock, do not use on wet surfaces or expose to rain.

GROUNDING INSTRUCTIONS

In the event of a malfunction or breakdown, grounding provides a path of least resistance for electric current to reduce the risk of electric shock. This machine is equipped with an electric cord having an equipment-grounding conductor and a grounding plug. The plug must be plugged into a matching outlet that is properly installed and grounded in accordance with all local codes and ordinances. Do not modify the plug provided – if it will not fit the outlet, have the proper outlet installed by a qualified electrician. Improper connection of the equipment-grounding conductor can result in a risk of electric shock. The conductor with insulation having an outer surface that is green with or without yellow stripes is the equipment-grounding conductor. If repair or replacement of the electric cord or plug is necessary, do not connect the equipment-grounding conductor to a live terminal.

Check with a qualified electrician or serviceman if the grounding instructions are not completely understood, or if in doubt as to whether the tool is properly grounded.

EXTENSION CORDS – If necessary use extension cords for 120V-16AWG and a maximum length of 50 feet only. Cords rated for less than the equipment may overheat. Care should be taken to arrange the cord so that it will not be tripped over or pulled.

Extension cords are not normally recommended.

Grounded, cord-connected tools intended for use on a supply circuit having a nominal rating less than 150 volts.

This machine is intended for use on a circuit that has an outlet that looks like the one illustrated in Sketch A. The machine has a grounding plug that looks like the plug illustrated in Sketch A. A temporary adaptor, which looks like the adaptor illustrated in Sketches B and C may be used to connect This plug to a 2-pole receptacle as shown In Sketch B if a properly grounded outlet is not available. The temporary adaptor should be used only until a properly grounded outlet can be installed by a qualified electrician. The green colored rigid ear, lug, etc. extending from the adaptor must be connected to a permanent ground such as a properly grounded outlet box.

GROUNDING METHODS

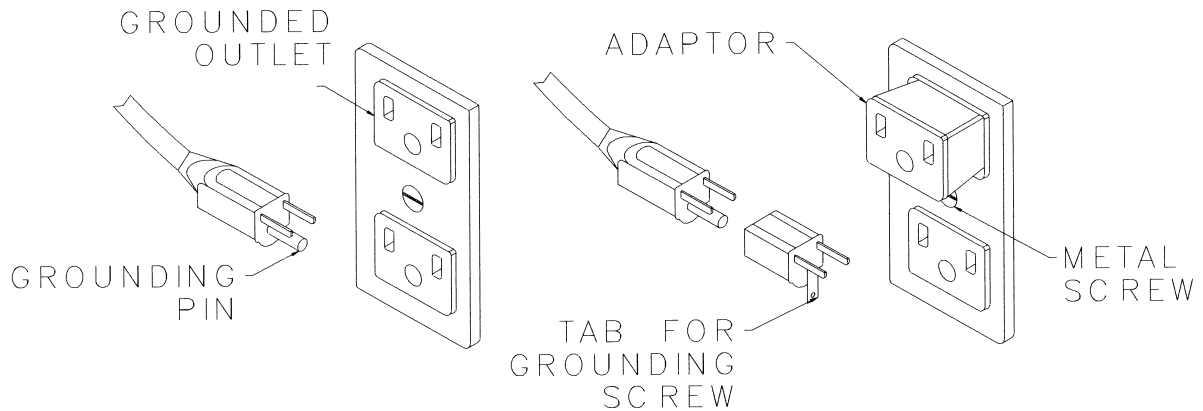

Note: In Canada the use of a temporary adaptor is not permitted by the Canadian Electrical Code.

REDUCE THE RISK OF UNINTENTIONAL STARTING – Make sure switches are in the “OFF” position before plugging cord in.

ALWAYS UNPLUG EQUIPMENT – from electrical outlet when not in use. Never use the cord to pull the plug from the outlet. Grasp plug and pull to disconnect.

SERVICING MACHINE – Disconnect machine before servicing as well as when changing accessories such as tool bits, carbide cutters, etc.

TO REDUCE THE RISK OF FIRE – Do not operate equipment in the vicinity of open containers of flammable liquids (i.e. gasoline).

WEAR PROPER APPAREL – No loose clothing, gloves, neckties, rings, bracelets or other jewelry which may get caught in moving parts. Wear protective hair covering to contain long hair. Non-slip footwear is recommended. Keep all parts of body away from moving parts of machine.

KEEP WORK AREA CLEAN – Cluttered areas and benches invite accidents. Do not let cord hang over edge of table, bench or counter.

REMOVE ADJUSTING KEYS & WRENCHES – Form a habit of checking to see that keys and adjusting wrenches are removed from tool before turning machine on.

DON'T FORCE MACHINE – Don't force machine or attachments to do a job for which they were not designed.

DON'T OVERREACH – Keep proper footing and balance at all times.

ALWAYS USE SAFETY GLASSES – Everyday eyeglasses only have the impact-resistant lens..they are **NOT** safety glasses.

KEEP GUARDS IN PLACE – and in working order. These are installed for your safety.

NEVER LEAVE MACHINE RUNNING UNATTENDED – Turn power OFF. Do not leave machine until it comes to a complete stop. Keep hands away from moving parts.

MAINTAIN MACHINE WITH CARE – Keep machine clean and in good condition for the best and safest performance. Follow instructions for lubricating and changing accessories.

CLEANING MACHINE – DO NOT USE COMPRESSED AIRLINE – use brush or shop vac when machine is not in use.

CHECK DAMAGED PARTS – Any part, guard or adaptor that is damaged should be carefully checked to determine if it will operate properly and perform its intended function. A guard, adaptor or other part that will not fulfil its intended purpose should be replaced or repaired.

NORMAL OPERATION – Machine must be bolted to bench before operation, thus eliminating the possibility of tipping, slipping and vibration on supporting surface.

READ INSTRUCTION MANUAL – on set-up and operation of machine **BEFORE** using. Use only as described in this manual. Use only manufacturers' recommended attachments.

SAVE THESE INSTRUCTIONS.

INSTALLATION AND SET-UP

- Uncrate the lathe and remove from the box.

Caution: Do not remove lathe by lifting up on the lathe arbor. There is danger of distorting the arbor and causing runout.

- Check the lathe thoroughly and report any damage to the carrier immediately.
- Bolt the lathe onto the bench. This will avoid possible vibrations when operating the lathe.

Note: If the lathe bench is used and placed on an uneven floor, it should be leveled or shimmed and bolted to the floor. If the floor is flat, it is not necessary to bolt bench to floor.

- Place lamp on the mounting lug located at the rear of the machine. Plug the lamp into the receptacle in the lower center of the spindle housing marked FOR LAMP USE ONLY.

Note: Do not plug other equipment into the outlet.

- Be sure the lathe is plugged into a grounded, 120 volt electrical outlet.

Note: The plug must fit into a matching outlet that is properly installed and grounded in accordance with all local codes and ordinances. Do not modify the plug provided. If it will not fit the outlet, have the proper outlet installed by a qualified electrician.

Caution: Do not cut off grounding prong. An improper connection can result in a risk of electric shock.

- The spindle bearings are permanently lubricated in the machine.
- Lubricate tool carriage ways and ALL lube points (Fig.1) with a good grade of lubricating oil.

Note: Lathe should be cleaned and oiled daily when in use.

- Clean the lathe arbor, the arbor threads, adaptors, cones and collars of protective coating. Then, lubricate adaptors and threads with light oil to protect against corrosion.

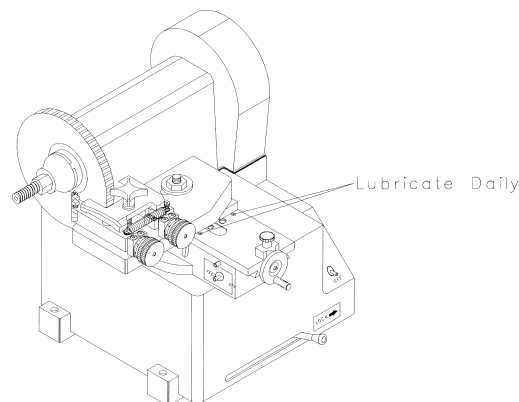

Fig. 1

CARRIAGE SETUP

The 1215 Series Combination Lathe is equipped with a carriage that can be positioned and locked at two positions, 90 degrees apart for resurfacing rotors or drums. The illustrations below show the machine setup in both positions.

In Figure 2 we show the carriage parallel to the spindle shaft with the boring bar assembly installed ready to resurface drums.

In Figure 3 we show the carriage rotated 90 degrees to the spindle with the twin cutter assembly installed ready to resurface rotors.

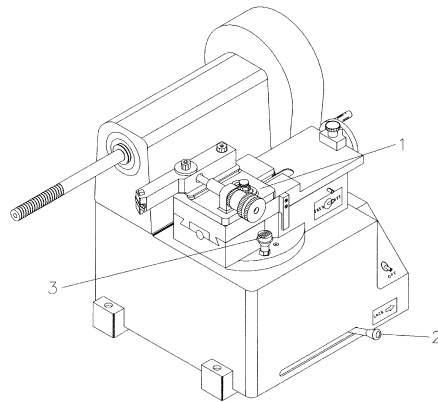

Fig. 2

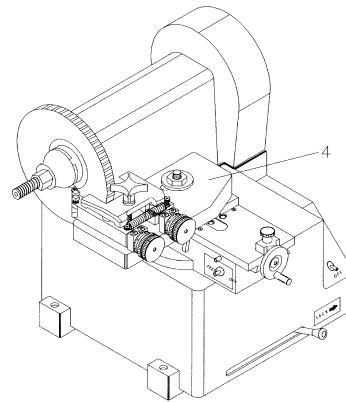

Fig. 3

1 DRUM TO ROTOR

To change position of carriage from drum (Fig.2) to disc (Fig.3).....

- Remove boring bar assembly (1)
 - Move lock lever (2) to the left "OFF" position
 - Lift the spring loaded locating pin (3) and turn the knob locking it up
 - Rotate the carriage to the left and release the locating pin. Continue rotating until the pin drops engaging the positioning hole
 - Move lock lever to the right "ON" position locking the carriage
- Install twin cutter assembly (4)

2 ROTOR TO DRUM

To change position of carriage from disc (Fig.3) to drum (Fig.2).....

- Remove twin cutter assembly (4)
 - Move lock lever (2) to the left "OFF" position
 - Lift the spring loaded locating pin (3) and turn the knob locking it up
 - Rotate the carriage to the right and release the locating pin. Continue rotating until the pin drops engaging the positioning hole
 - Move lock lever to the right "ON" position locking the carriage
- Install boring bar assembly (1)

MOUNTING BRAKE DRUMS

1 Drum with Hub

Remove the wheel bearings from the hub and clean the outer bearing races thoroughly. Select the bearing adaptors that fit the bearing races, one for each end of the hub. Mounting is similar to rotors with hub – see Fig.7A.

2 Drum without Hub

Select the taper cone that fits the center hole of the drum. Select the proper hubless adaptors to fit the inside and outside of the drum, Use the coil spring as shown in Fig.4A.

Caution: Be sure the surfaces of the tapered cone and drum center are thoroughly cleaned. It is often necessary to dress the center hole inner and outer wheel mounting flange with a fine file or sand paper. Dirt or build-up of rust in drum center will cause inaccurate truing of drum surfaces.

Note: The tapered cone and spring can be mounted on either side of drum. On small drums, they are always mounted on the outside of drum.. See Fig.4B.

- Tighten the spindle locking collar tightly. Do not use excessive force.
- Install the drum chatterband tightly around the outside of the drum. Chatterbands must be used to eliminate vibration.

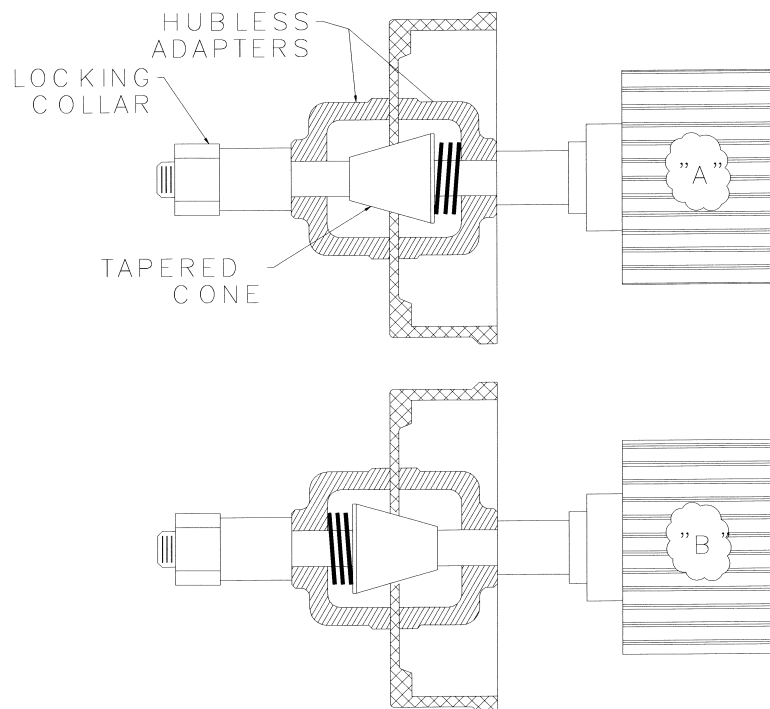

Fig.4 Typical mounting of drums on lathe arbor

OPERATING THE LATHE (Brake Drums)

Note: Before proceeding make sure all switches are in the “OFF” position and the carriage is locked in the drum position. See Carriage Setup page 6, Fig.2.

SETTING DRUM BORING BAR ASSEMBLY

- Install the drum boring bar assembly on the carriage by inserting the center post into the tee slot and sliding it into position
- Adjust the boring bar (2) and cutting tool (3) to line up with the drum braking surface and tighten the center post locknut (4) firmly.

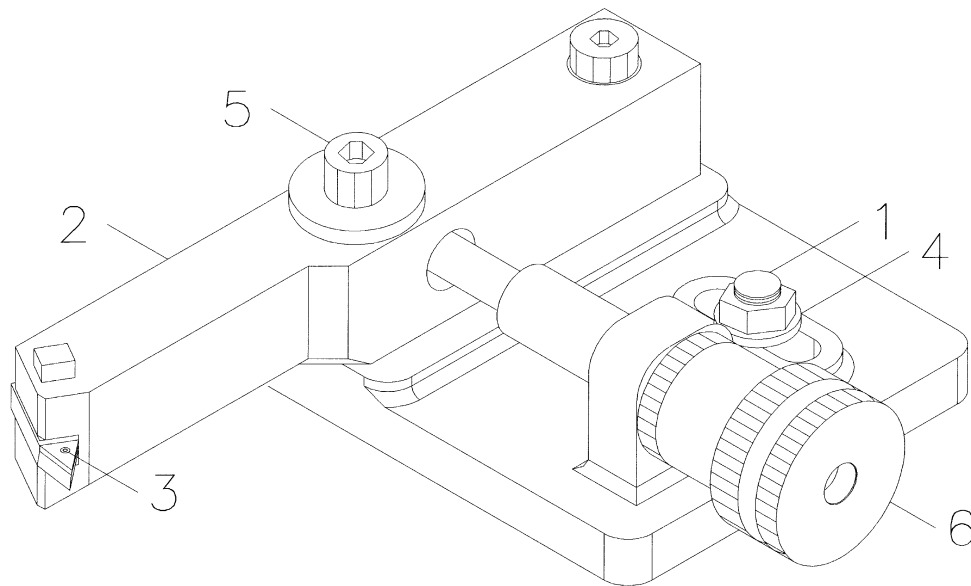

Fig. 5

SETTING CUTTING TOOL

- Loosen the boring bar clamping bolt (5)
- Turn the tool positioning knob (6) clockwise to position the cutting tool close to the braking surface.

Note: Be sure the cutting tool will travel over the full surface of the drum before shutoff arm turns the carriage feed off.

SETTING DEPTH OF CUT (Brake Drums)

- Start the brake lathe by moving the spindle switch (1) to the “ON” position.
- Turn the cross-slide carriage handwheel (2) and position the cutting tool (3) (carbide insert) inside the drum.
- Turn the tool positioning knob (4) clockwise until the cutting tool touches the drum surface.
- Hold the tool positioning knob (4) to keep it from turning and adjust the inner sleeve (5) until zero or one of the reference numbers on the scale aligns to the benchmark located on the support block.

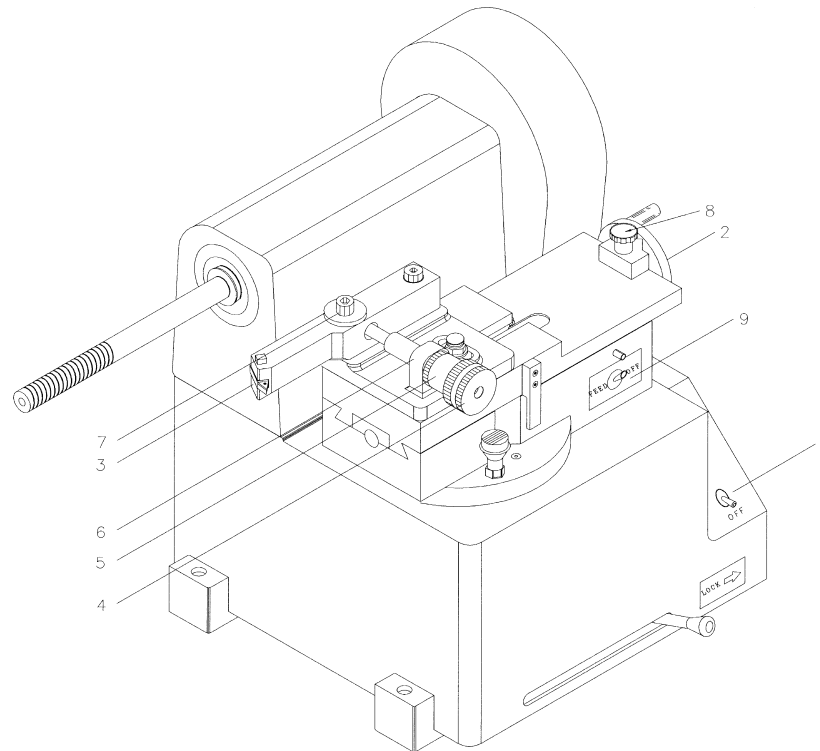

Fig. 6

Note: Each graduation on the adjusting knob equals .004”.

- Wind carriage into back of drum cutting surface.
- Now turn the tool positioning knob to the desired depth of cut, noting the number of graduation lines past the set reference number. Tighten the boring bar clamping screw (7).

Note: Recommended depth of cut is .005 to .010.

- Do not try to cut too much at one time. Smaller cuts produce a finer finish.
- With depth of cut set, tighten the carriage feed locking knob (8) and turn the automatic carriage feed switch (9) to “ON”.

Note: The carriage feed will stop automatically when the cut is complete. The cutting tool boring bar and cutting tool bit feeds from inside of the drum outward.

- If a second cut is necessary, loosen the carriage feed locking knob and repeat above procedure.
- When the drum braking surface is refinished and trued, move the lathe spindle switch to "OFF".

Caution: Spindle shaft, cones, adaptors and spacers must be kept clean and free of nicks to ensure proper alignment of the drum on the arbor. Failure to follow this procedure will result in drums not running true with bearings, thereby causing problems in the braking system of the vehicle.

CLEANING THE LATHE

Be sure lathe is turned off. Brush or vacuum chips from the lathe and bench.

CAUTION: Do not use compressed air for cleaning this lathe.

MOUNTING BRAKE ROTORS

1 Rotor with Hub

Remove the wheel bearings from the hub and clean the outer bearing races thoroughly. Select the bearing adaptors that fit the bearing races, one for each end of the hub. Mounting is similar to drums with hub – see Fig.7A.

2 Rotor without Hub

Select the taper cone that fits the center hole of the rotor. Select the proper hubless adaptors to fit the inside and outside of the rotor. Use the coil spring as shown in Fig.7B.

CAUTION; Be sure the surfaces of the tapered cone and rotor center are thoroughly cleaned. It is often necessary to dress the center hole inner and outer wheel mounting flange with a fine file or sand paper. Dirt or build-up of rust on rotor centers will cause inaccurate truing of the rotor surfaces.

Note: The tapered cone and spring can be mounted on either side of rotor. On small rotors, they are always mounted on the outside. See 7C.

- Mount the brake rotor on the arbor using the adaptor(s) and spacers.

Note: The brake rotor should be mounted as close to the lathe housing as possible. This provides a good stable mounting for best refinishing results

- Tighten the spindle locking collar tightly. Do not use excessive force.
- Install the silencer band on the rotor to eliminate vibration.

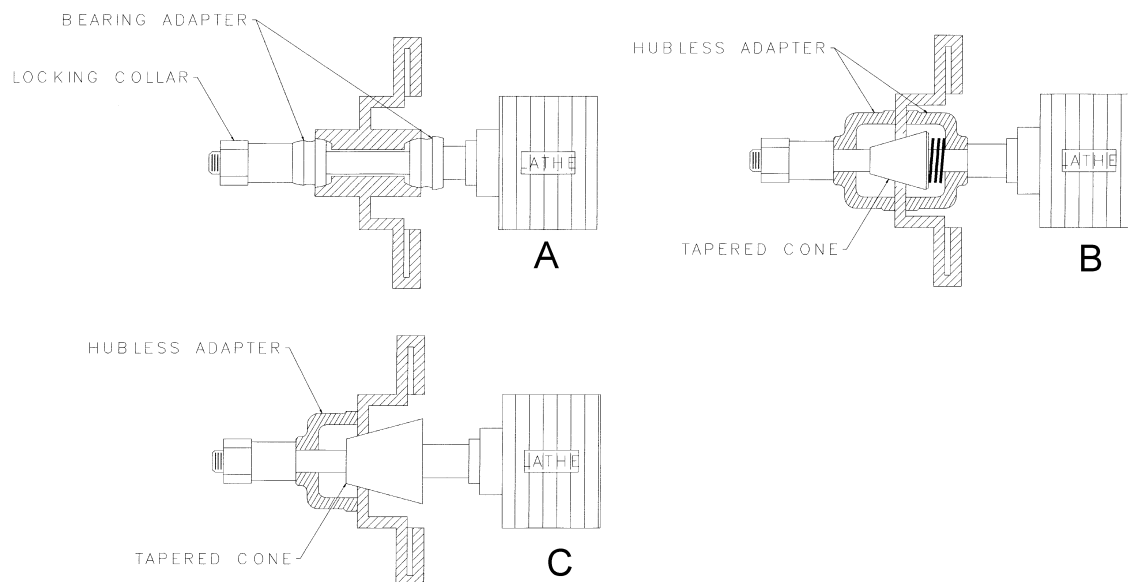

Fig.7 Typical mountings of rotors

COMPOSITE ROTORS

Some late model automobiles use use “composite” rotors. To resurface these rotors within manufacturers’ specifications, special tooling has been developed. This tooling clamps the rotor so that close machine tolerances can be kept and a proper surface is produced. Failure to use this special tooling will result in an out-of-tolerance rotor surface. The rotor may exceed specifications concerning parallelism and runout. This can cause brake pedal pulsations, noise and reduce life of the brake components.

NON-DIRECTIONAL ROTOR REFINISHER

To follow the recommendation of some automobile manufacturers specifications, a non-directional or “swirl” finish may be required. This finish is to be applied to a resurfaced rotor. Always check the manufacturers specifications.

Composite rotor tooling and non-directional finishing tools are available upon request.

OPERATING THE LATHE (Brake Rotors)

Note: Before proceeding make sure all switches are in the “OFF” position and the carriage is locked in the rotor position. See Carriage Setup page 6, Fig.3.

SETTING ROTOR TWIN CUTTER ASSEMBLY

- Install the rotor twin cutter assembly on the carriage by inserting the center post (1) into the tee slot and sliding it in place.
- Position the cutting tools (2) equally on both side of the rotor and tighten the center post locknut (3) firmly.

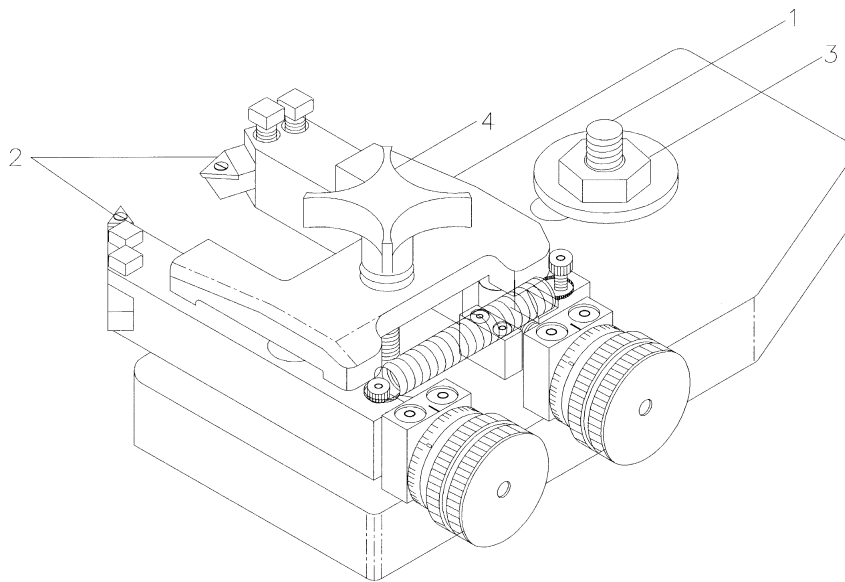

Fig. 8

SETTING THE TOOLS

- Loosen twin cutter clamp knob (4)
- Adjust both cutting tools (2) to line up close to the rotor braking surfaces.

Note: Be sure the cutting tools will travel over the full surfaces of the rotor before shutoff arm turns the carriage off.

SETTING DEPTH OF CUT (Rotors)

- Start the brake lathe by moving the spindle switch (1) to the ON position.
- Turn the cross-slide carriage feed handwheel (2) and move carriage in until the cutting tool bits (3) are positioned over the braking surface of the rotor.
- Turn tool positioning knob (4) on one side until the cutting tool bit touches the surface of the rotor. Set the cutting tool bit on the other side of the rotor the same way.
- Move the carriage in until the cutting tools are just inside the undercut of the rotor.
- Hold the tool positioning knob to keep it from turning and adjust the inner sleeve (5) until zero or one of the reference numbers on the scale aligns to the benchmark located on the support block (6). Repeat this procedure on the other positioning knob.

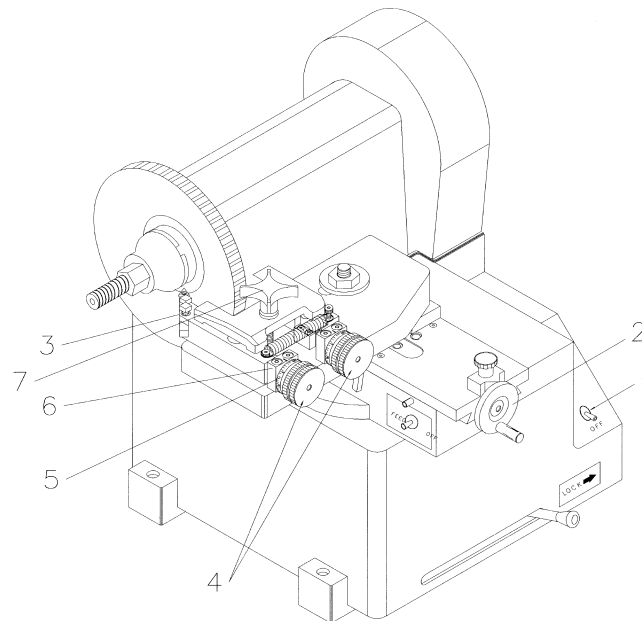

Fig. 9

Note: Each graduation line on the inner sleeve of the tool positioning knob is .002" (.05mm).

- Turn the tool positioning knobs (4) to the desired depth of cut, noting the number of graduation lines past the set reference number.

Note: Recommended depth of cut is .006"-.010" on each rotor surface or three to five graduation lines.

- Do not try to cut too much at one time. Smaller cuts produce a finer finish.
- With depth of cut set, tighten the twin cutter clamp knob (7).
- Tighten the carriage feed locking knob and turn the automatic carriage feed switch "ON".

Note: The carriage feed will stop automatically when the cut is complete.

- If a second cut is necessary, loosen the carriage feed locking knob. Turn the carriage feed handwheel and move the carriage in until the cutting tool bits are just inside the undercut of the rotor. Then repeat above procedure.
- When the rotor braking surfaces are refinished and trued, move the spindle switch to "OFF".

Caution: Do not shut lathe off while cutting tool is in contact with the rotor. This will cause the carbide cutters to chip and render them useless.

Caution: Spindle shaft, cones, adaptors and spacers must be kept clean and free of nicks to ensure proper alignment of the rotor on the spindle. Failure to follow this procedure will result in rotors not running true with bearings, thereby causing problems in the braking system of the vehicle.

CLEANING THE LATHE

Be sure the lathe is turned off. Brush or vacuum chips from the lathe and bench.

CAUTION; Do not use compressed air for cleaning this lathe.

ARBOR REMOVAL AND INSTALLATION

The Combination Brake Lathe is equipped with a standard 1" diameter arbor. This arbor is removable to allow the installation of an optional arbor.

TO REMOVE;

- Loosen the draw bolt three or four turns using W221 wrench. See Fig.10.
- Tap the end of the draw bolt with a plastic hammer to loosen the shaft taper.
- Hold the arbor and unthread the draw bolt. The arbor will slip free of the tapers of the spindle.

TO INSTALL;

- Clean both tapers (arbor and spindle) to remove any foreign material. Dirt on these surfaces will cause shaft runout.
- Slide the arbor into the spindle. Align the "O" marks on both until they are in line with each other as shown in Fig.10. Tighten the draw bolt.

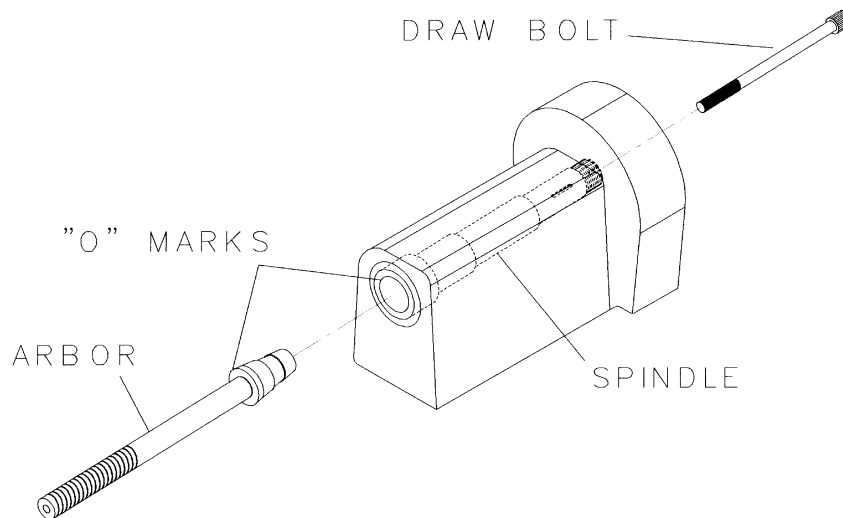

SERVICE AND MAINTENANCE

LUBRICATION

- The spindle bearings are permanently lubricated.
- Lubricate tool carriage ways and **ALL** lube points with a pressure type oil can using S A E 10 oil.

Note: Lathe should be cleaned and oiled daily when in use. This will assure minimum wear of lathe gibs and ways.

CLEANLINESS

- Clean the lathe daily when in use. Use a suitable brush or cloth. A vacuum cleaner may also be used.

Caution: Never use compressed air.

CUTTER BITS (Carbide Inserts)

- The tri-corner tool bits allow for three cutting edges.
- To replace or to rotate to a new cutting edge, remove the cutter bit mounting screw. Be sure mounting screw is tightened firmly after changing the cutter bit.

Note: It is recommended to maintain a chart or record whenever cutter bits are replaced or rotated.

Note: Cutter bits are changed whenever a rough or wavy finish appears on the braking surfaces of the drum or rotor. This indicates a worn or chipped cutting edge.

TROUBLE SHOOTING

PROBLEM: Main motor will not run!

Cause: The overload switch on the motor cuts in due to overloading the motor with a large cut or using a very long extension cord between the power source and the machine.

Remedy: Let motor cool down, then push reset button on back of motor.

PROBLEM; Rough finish on disc and drum.

Cause: Worn or broken tool bit.

Remedy: Index carbide to new corner or replace.

Cause: Drum boring bar or tool holder is not a proper angle.

Remedy: Loose locking bolts on center post of the drum turning attachment and position it to obtain a more optimum angle (inward toward drum surface).

Cause: Loose tool cutter.

Remedy: Check that the tool cutter clamping bolts are tight.

Cause: Excessive play in main slide carriage.

Remedy: The main slide carriage is adjustable for play by means of a row of bolts along the lower left edge of the carriage. These bolts have locknuts to keep them in place. Loosen the locknuts and adjust the screws until there is a slight drag when moving the carriage back and forth. Tighten the locknuts while holding the adjusting screws in place.

Note: Carriage must be over dovetail plate while adjusting the carriage for excessive play.

Cause: Cut is too large.

Remedy: Do not try to cut too much at one time. Smaller cuts produce a finer finish.

Cause: Speed control set on rough cut. (1215V lathe).

Remedy: Slow feed down. No feed adjustment on 1215S lathe.

PROBLEM: The end of the arbor wobbles when a drum or rotor is mounted

Cause: Sometimes when a rotor, flywheel or drum is mounted, the end of the shaft will wobble. When the arbor nut is loosened the shaft will run true. This is NORMAL. Rotor and drum surfaces are rarely flat. When tightening the arbor nut, the arbor will twist toward the lowest part of the mounting surface.

Remedy: What can be done to reduce wobble:

- Prepare the surfaces the tooling will touch to insure they are flat and smooth. If machining a hubless part, use a file to dress the center hole at the point where the mounting cone will touch. If a hub type, wipe out the old grease and inspect the bearing races for wear or unevenness. Replace if necessary. Remove sharp edges and burrs.
- Use the self-aligning washers (W224 and W223) found in the tooling supplied with the lathe. Place the self-aligning washers on the arbor just after the last cup, bearing adaptor or cone.
- Insure the tooling is clean and free of nicks.
- If machining a rotor, use a dial indicator with the rotor mounted on the vehicle to find the high spot on the friction surface. Mark the high spot. Remove the rotor, mount it on the brake lathe and use a dial indicator to check for the location of the high spot. If they differ, re-adjust the tooling and adjust until the high spot agrees with the mark found when mounted on the vehicle.
- As an alternate method to above or when machining a drum, do a scratch test:
 - Mount the drum, rotor or flywheel and switch the lathe on
 - Adjust the cutting bit until it just touches the friction surface
 - Back the cutter from the surface and turn the lathe off. The scratch in the surface will indicate the high spot.
 - Loosen the tooling and rotate the part 180deg. (without rotating the tooling). Tighten.
 - Move the line cutter to another spot on the friction surface and make another scratch test. If the scratches line up, the part is properly mounted and can be machined. If the scratches do not line up, loosen and adjust the tooling until they do.

PROBLEM; The arbor wobbles without a drum or rotor mounted.

Cause: The arbor has not been properly installed.

Remedy: To insure true running, make sure the "O" witness marks found on the arbor and lathe shafts are aligned and the arbor is tight. See the ARBOR REMOVAL AND INSTALLATION section of this manual.

Cause: The arbor is bent. Using a dial indicator measure the runout of the arbor about six inches from the headstock. The allowed tolerance is 0.001”(0,025mm).

Remedy: Replace the arbor.

PROBLEM; Fish scale pattern in the machined surface.

If rotor only:

Cause: The rotor silencer has not been used.

Remedy: Attach chatterband.

Remedy: Attach rotor stabilizer to machine. The rotor stabilizer should be attached so that the plungers are pushing against the friction surface with even pressure. When machining thin, solid, non-vented rotors, the silencer bands can be used with the stabilizer to give extra vibration dampening.

If drums & flywheels only:

Cause: The angle of the boring bar is incorrectly positioned.

Remedy: Adjust the bar in the holder so that a minimum of the bar at the cutting bit end is exposed. Adjust the angle of the boring bar holder so the cutting bit is pointing as close as possible to a right angle to the friction surface. The tip of the bit should be used for machining, not the side.

Cause: If a drum, the silencer band was not used or is attached incorrectly.

Remedy: Attach the band tightly so that it covers as much of the drum as possible. If turning especially wide drums, it may be necessary to use a second silencer band BDL 140.

If drums, flywheels or rotors:

Cause: The part has been mounted too far out on the arbor.

Remedy: Always mount the part to be machined as close to the spindle housing as possible.

Cause: The bench is not tightly bolted together. The lathe is not bolted to the bench or the bench can rock on the uneven floor.

Remedy: Tighten the bench hardware. Make sure the lathe is bolted securely to the bench. Adjust the legs to insure the bench will not rock.

Cause: The carriage feed speed is set too low.

- Remedy: Increase the feed speed. Acceptable machining is usually maintained with the adjustment knob set to the 3 o'clock scale position. **Note:** 1215S lathe does not have variable carriage feed.
- Cause: The cutter bit(s) are loose or chips are lodged between the bit and the holder or the holder(s) is loose.
- Remedy: Remove the carbide bit(s). Clean any chips from the holder. Tighten the bit attachment screw and the holder mounting screws.
- Cause: The arbor drive motor v-belt is defective or the motor is loose, causing a vibration throughout the lathe and bench.
- Remedy: Replace the v-belt. Tighten the motor.
- Cause: The depth of cut is set too small.
- Remedy: Adjust depth of cut to remove at least 0.002".
- Cause: The wrong carbide cutter bits and/or holder is used.
- Remedy: Use the proper bits and holder. The correct bits are positive with a 0.015" radius, PN W139. The holder part number is W140.
- Cause: Not enough support.
- Remedy: Use largest hubless adaptors possible. Always use two (one each side).

Standard Tooling 201

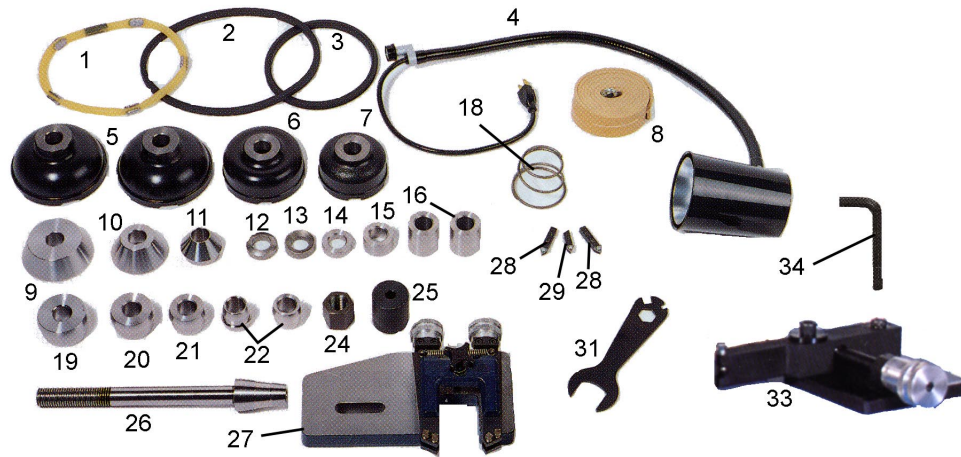

1	W117	Chatterband
2	W116	Chatterband
3	W131	Chatterband
4	BDL251-1	Lamp
5	CW96	Hubless Adapter 1" bore, 5.5" diameter (2)
6	W115	Hubless Adapter 1" bore, 4.75" diameter
7	W114	Hubless Adapter 1" bore, 4" diameter
8	BDL140	Chatterband
9	W110	Cone 1" bore, 3" to 4"
10	W111	Cone 1" bore, 2" to 3.125"
11	CW94	Cone 1" bore, 1.150" to 2.350"
12	W223	Self-Aligning washer Convex
13	W224	Self-Aligning washer Concave
14	W98	Spacer 1" bore, 1/2" long
15	W99	Spacer 1" bore, 1" long
16	W101	Spacer 1" bore, 2" long (2)
18	W108	Spring
19	W129	Bearing adapter 1" bore 2.407" to 2.781"
20	W119	Bearing adapter 1" bore 2.033" to 2.407"
21	W133	Bearing adapter 1" bore, 1.659" to 2.033"
22	W118	Bearing adapter 1" bore, 1.285" to 1.659" (2)
24	W220	Nut
25	CL622	Spacer
26	CL538	Arbor 1" bore, 10.5" long
27	CL605A	Disc Tool Plate
28	W140	Tool bit holder with bit
29	W140-1	Tool bit holder with bit
31	W221	Wrench
33		Drum Tool Plate
34	CL130-1	Allen wrench

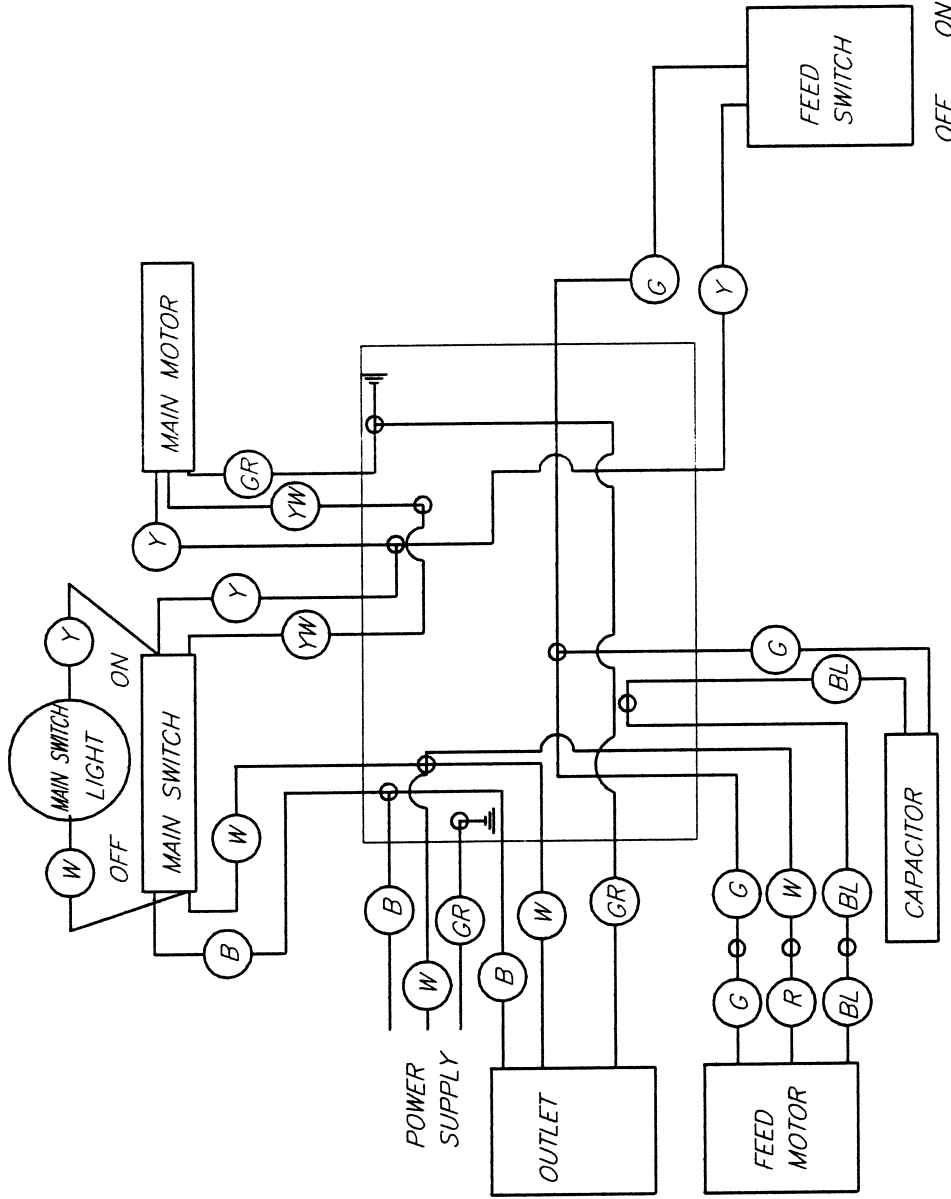

1	D.H.	11/01	NEW CAD DRAWING
REV.	BY	DATE	DESCRIPTION
<p>TOLERANCES UNLESS OTHERWISE SPECIFIED DECIMAL .XX ±0.010 .XXX ±0.005 FRACTIONAL ± 1/64 ANGULAR ± 30' 125/</p>			
<p>SCALE: DO NOT SCALE</p>			<p>DESCRIPTION: 201 STANDARD 110V</p> <p>MATERIAL:</p> <p>PART No:</p> <p>DATE: 26/11/01</p>
DRAWN BY: D. HARDILL			SCALE: DO NOT SCALE

W	WHITE	YW	YELLOW	WHITE	G	GREY
B	BLACK	YB	YELLOW	BLACK		
Y	YELLOW	GR	GREEN			
R	RED	BL	BLUE			